



#### Systems Include:

- Crank or motor driven unit
- Two 8 ft. sections of flexible tubing
- Two 10 ft. sections of flexible tubing
- Four lift cylinders
- Four glides
- Twelve tubing clips (adhesive backed) and sixteen cable ties
- Installation tips
- Drilling templates

Ergoswiss Quick Ship Systems are shipped completely assembled and ready for installation.

## Quick Ship Systems

### TECHNICAL DATA

- Maximum lift capacity 1000 Lbs. (450 kg)
- Adjustment range 8" / 12" / 16" (200/300/400 mm)
- Motor or crank driven
- Other models upon request



1000 lbs	Linear Unit LA		Crank System			Motor System
System Adjustment Range	Dimension A [mm]	Dimension B [mm]	Part Number	X	Y	Part Number
8"	317	240	111.00042	600.5	585.5	111.00052
12"	442	340	111.00043	722.5	707.5	111.00053
16"	542	340	111.00044	923.5	908.5	111.00054

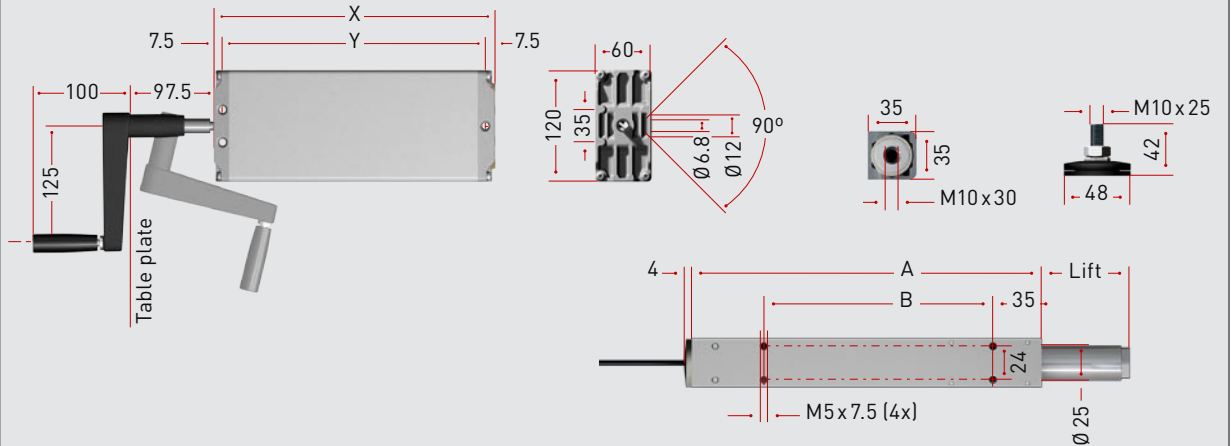

**Additional products**

Table system TA

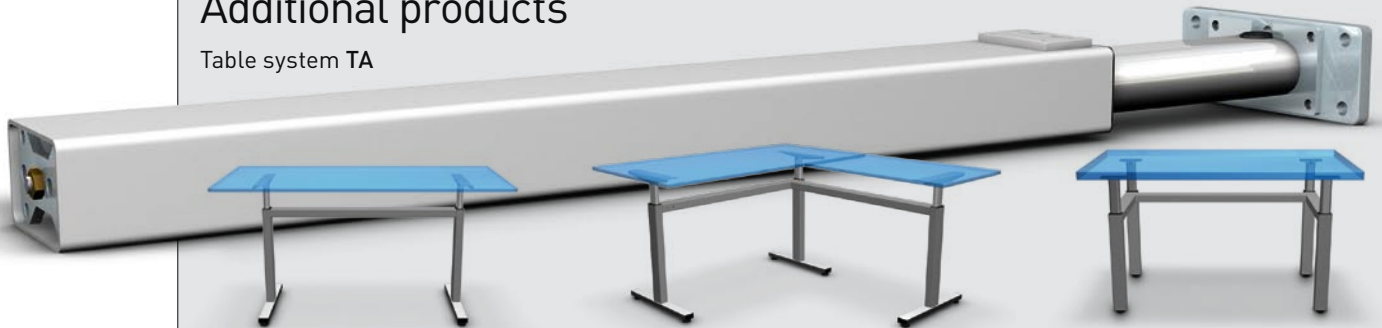

Linear units



Cylinders



Electric Drives

